

PRODUCT OVERVIEW

Brakes
Solutions >

SIME BRAKES
INDUSTRIAL BRAKING SYSTEMS



WORLD LEADING MANUFACTURER OF BRAKING SYSTEMS >



GKN Stromag France is a world leading manufacturer of industrial brakes.

Constant attention to evolving needs and its effort to focus its product development on quality and innovation allow our company to meet global supply requirements with standard or fully customised braking systems solutions.



At **GKN Stromag France**, the accent is placed firmly upon research and innovation.

That is why every year, the company invests heavily into Research and Development to provide leading edge products. With in-depth knowledge and experience in all key applications and markets, the company keeps constantly abreast of the every changing needs and market development.

The R&D department uses unique test facilities like the braking simulation tower and many dynamic benches allowing to test the brakes under real operating conditions.



In a mutually beneficial way, **GKN Stromag France** creates a strong relationship with its customers in order to understand their needs and provide them the best solution.

GKN Stromag France engineers and technicians are developing with its customers the brakes of tomorrow.

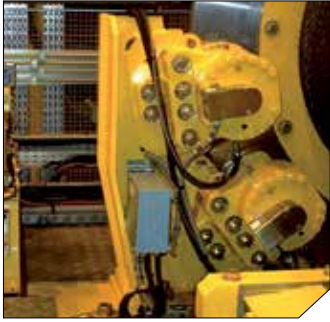

With more than 60 years of experience in the supply of high efficiency braking systems, **GKN Stromag France** provides disc brakes certified by recognised authorities such as DNV, ABS, TUV, Lloyd's Register and EDF. The certification ISO9001 of our management system of Quality was renewed under the version ISO 9001 - 2008 in 2012.

SOLUTIONS FOR YOUR APPLICATION >



GKN Stromag France is particularly active in traditional areas such as steel industry, nuclear plants, port applications and mass transport as well as on fast-growing markets such as offshore applications.

- > Steel cranes
- > Nuclear cranes
- > Offshore winches
- > Port cranes
- > Belt conveyors
- > Tower cranes
- > Mass transport
- > Theatres winches



Whatever the application, even in Theatrical applications, **GKN Stromag France** can supply, to ensure the best reliable performance in safety, a complete braking solution for :

- > heavy braking applications, in aggressive, high temperature and dust laden conditions such as the Iron and Steel Industry.
- > high safety requirements such as Nuclear Plants (customers in France, Europe, China, Brazil, and South Korea).
- > offshore and marine applications where reinforced anti-corrosion protection is required against the harsh atmosphere.
- > high demand rate braking such as Port Crane applications,
- > smooth braking, under all conditions, for the use in conveying people, such as Elevators, Escalators and Cable Way cars.
- > controlled or regulated braking, under all load conditions, for applications such as materials handling conveyors.



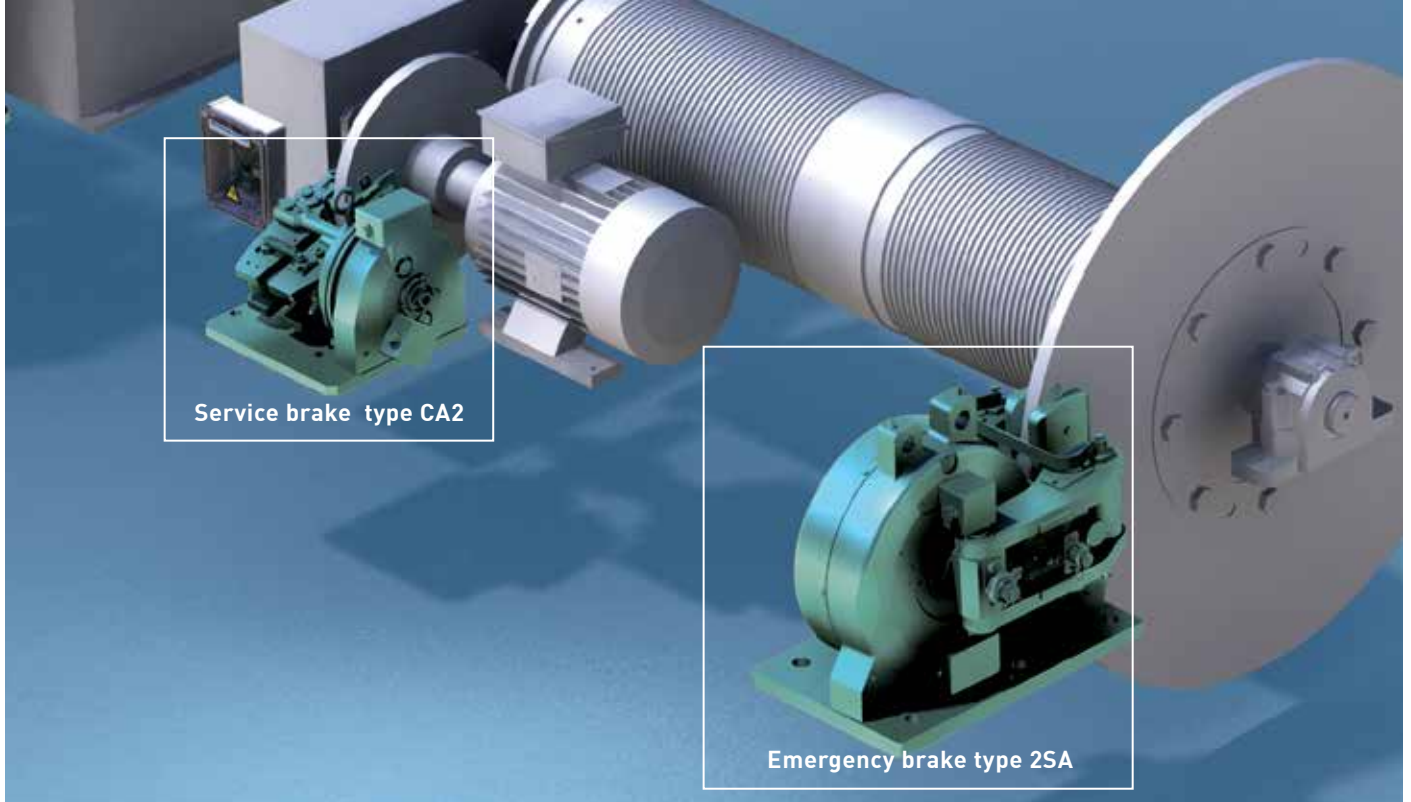

SERVICE BRAKES

> CA2 RANGE



Braking torque 665 - 8040 N.m
Disc Ø445 to 995

The **CA2** range was designed initially to equip the iron and steel cranes with heavy actuations, ensuring safety and reliability for dynamic braking. Today, the range answers the constraints of high-performance braking, whatever the application or conditions.

> 600 RANGE



Braking torque 33 - 1104 N.m
Disc Ø175 to 625

This economic range is composed of the **660**, **650** and **645** brakes. The **660** brake can be mounted with discs thickness 15 mm and the **650** and **645** with discs thickness 15 and 30 mm.

> 5K/5D & 45K/45D RANGE



5K braking torque 48 - 552 N.m
45K braking torque 287 - 1188 N.m
Disc Ø315 to 625

Compact and simple to adjust, the **5D/5K** brakes are the smallest electromagnetic brakes of the range. They can be mounted horizontally or vertically whatever the application and they can operate up to 600 cycles (actuations) per hour.

Based on the design of **5K/5D** brakes, the **45K/45D** complete the range of electromagnetic service brakes.

ELECTROMAGNETIC BRAKES

The fail-safe electromagnetic brakes are closed by spring application and opened electromagnetically (Electromagnetic release).

Service brakes are installed on the high speed line of the gearbox.

These brakes follow motor ratings and can be equipped with a automatic wear compensation, ensuring a constant torque whatever the wear of the lining pads. For our electromagnetic brakes range, the braking torque starts from 50 to 8000 Nm, with a disc having a standard diameter from 175 mm to 995 mm.

Emergency brakes are installed directly on the flange of the drums, and they are the last safety device in the event of a falling load.

These brakes are applied in case of overspeed detection, power failure, mechanical transmission breakage or emergency stop controlled by operator.

EMERGENCY BRAKES

> SA RANGE



2SA
Braking force 100 kN



OOSA
Braking force 60 kN

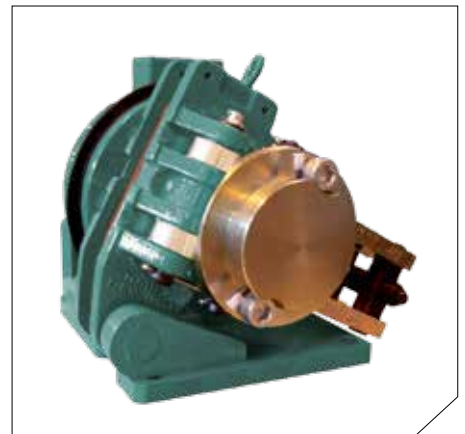

OSA
Braking force 31 kN

SA range is composed of **OSA**, **OOSA**, and **2SA** brakes.

This last one being the most powerful electromagnetic brake on the market. With optimum reliability, these brakes ensure the safe lifting of loads, essentially in the Steel Industry, where the **OSA**, **OOSA** and **2SA** have an unrivalled reputation.

This range has low maintenance levels and offers an incomparable reliability. When this brake is connected to a **4205** electrical power unit, manual lowering of loads is possible.

The **SA** range can be equipped with several options such as: Hydraulic release - Breather pot - Special paint - Steel cover for air gap seal....

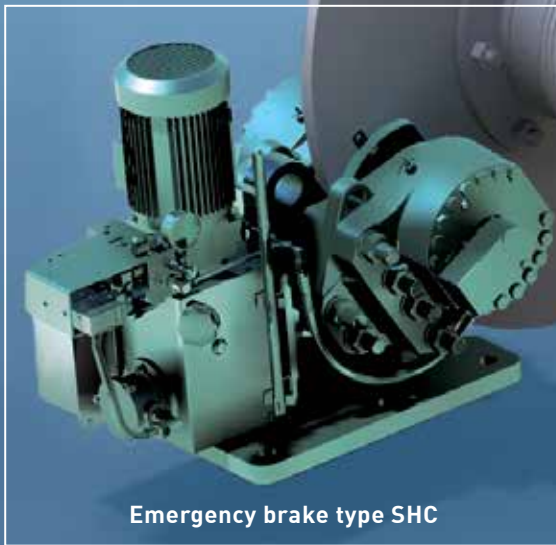

Emergency brake type SHC



Service brake type FAV

SERVICE BRAKES

> FAV RANGE

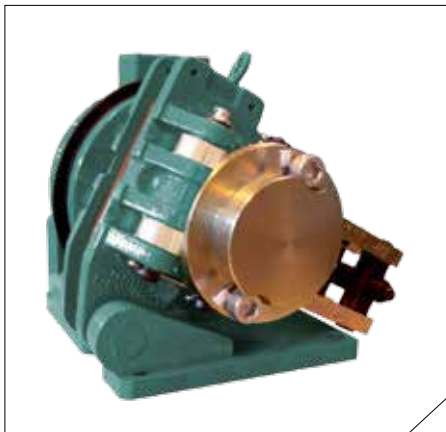

Braking torque 221 - 21 270 N.m
Disc Ø220 to 995

The **FAV** range has become very popular for use on large size cranes, where braking torques are escalating with the increase of crane capacities. Extremely reliable, the **FAV** can be fitted with either the ELDRO thruster or the SIME VS type.

> T RANGE



Braking torque 775 - 17 300 N.m
Disc Ø445 to 995

With the « **T** » fail-safe range, the braking torque is obtained thanks to its exclusive **HYDROSPRING** system which offers an incomparable braking torque stability. The **T** range can be used on cranes to handle heavy work loads and assembled with different types of options to suit customer applications.

> DRUM BRAKE RANGE



Braking torque 60 - 11 000 N.m
Drum Ø150 to 750

As a complement to our disc brakes, **GKN Stromag France** offers a full range of drum brakes equipped with Electro-Hydraulic Thruster.

This range of brakes is proposed when the mechanical constraints are not an overriding factor.

HYDRAULIC BRAKES

The fail-safe hydraulic brakes are closed by spring application and opened electro-hydraulically.

Hydraulic brakes are more powerful than electromagnetic range and can be used equally for the same applications or conditions.

For our service hydraulic brakes range, the braking torque starts from 60 to 21270 Nm, with a disc having a standard diameter from 150 to 995 mm.

As electromagnetic brakes, hydraulic emergency brakes are installed directly on the flange of the drums, and they are the last safety device in the event of a falling load.

These brakes are also applied in case of overspeed detection, power failure, mechanical transmission breakage or emergency stop controlled by operator.

EMERGENCY BRAKES

> SH RANGE

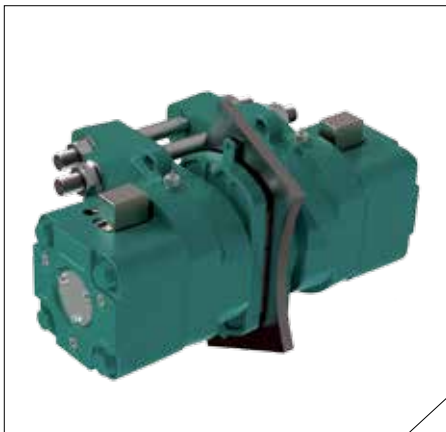

Braking force 11 - 333 kN

SH brakes are powerful hydraulic brakes with a symmetrical design. They are specially designed to operate in severe conditions. Robust build and simplicity of operation earn high customer approval for quality and safety.

> SHC RANGE



Braking force 11 - 333 kN

The **SHC** disc brake integrates the hydraulic power pack and the mounting bracket into one complete package. Brakes of **SH/SHC** range can be fitted with several options to meet customer application.

> SHD RANGE



Braking force 11 - 100 kN

The **SHD** range is a monospring fail-safe emergency brake; it can be mounted on tower crane, automotive cranes, and also on Wind Turbines. This makes it ideal to assemble and operate in restricted space.

POWER UNITS



ELECTRICAL SUPPLY UNITS

GKN Stromag France electrical power units guarantee a fast opening and closing time of the fail-safe electromagnetic brakes.

They have an “economic” mode which decreases the electric consumption and the heating of the brakes to provide an efficient and long lasting solution.

Protected against overload and overcurrent, this range of power units ensures safe, reliable and high performance of your braking system.

> AC64 & AC32



The new switch-mode power supply units, type **AC64**, **AC32** and **AS100**, offer high quality and braking performance.

They are equipped with a current control system to limit the loss of force at 30%.

> AS100



AC64, **AC32** and **AS100** electrical power units are available in Polycarbonate enclosure (CP): IP66, IK 8 or Steel enclosure (CA): IP66, IK 9

> 4200 & 4205



The electrical unit type **4200** is designed to control the opening and closing of the emergency shutdown electromagnetic brakes.

The electrical unit type **4205** includes an additional option which allows a progressive release of electromagnetic calipers to perform lowering actuations.

Casing protected version (**C4200**) and panel mount version (**P4200**) are both available.

BENEFITS >

- > Simplicity of adjustment and use
- > Weight and size reduced
- > Quick diagnosis of faults through the use of six leds

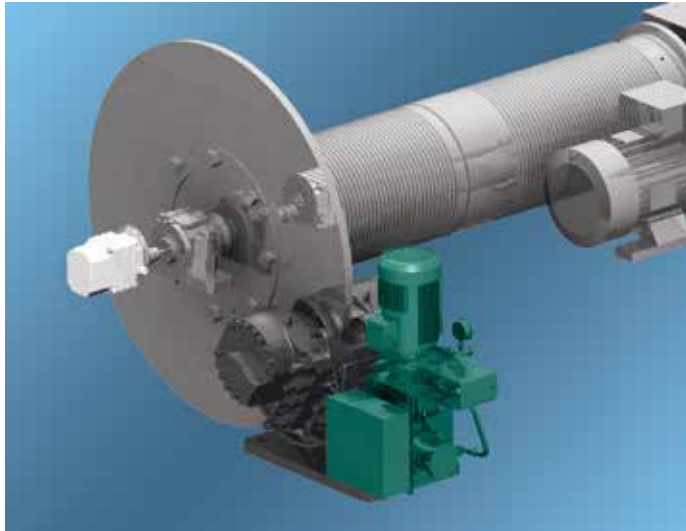

HYDRAULIC POWER PACKS

Use of emergency brakes implies a perfect control of opening and closing times.

This is why we designed and developed special hydraulic power packs adapted to these critical industrial constraints.

> CE8L



Tank 8 L
Max. pressure 225 bars

> CE12L



Tank 12 L
Max. pressure 225 bars

> ST210



Tank 63 L
Max. pressure 225 bars

A COMPLETE RANGE FOR YOUR NEEDS >

Whatever the type or the number of brakes necessary for your installation, whatever the distance that separates the braking system from the power unit, **GKN Stromag France** is able to provide a fitted solution to meet your needs. Many options are available :

- > Enhanced security return circuit
- > Manual lowering with dead man safety device
- > Manual lowering with overspeed safety by EV
- > Switches indicating valves position
- > Regulated braking by proportional limit valve
- > Clogging indicator
- > Oil temperature indicator
- > Electrical oil level indicator
- > Electrical box

SIDEOS One MODULE



SIDEOS One is a programmable and secure module for speed monitoring, fitted with an efficient auto control system which secures the overall operation of the overspeed detection system.

It allows to obtain, when installation is correct, a speed monitoring system secure up to category 4 with the performance level of $pL = e$ according to the standard ISO/IEC 13849-1.



ASSOCIATION OF 2 SIDEOS One > Detection of any kinematic linkage break

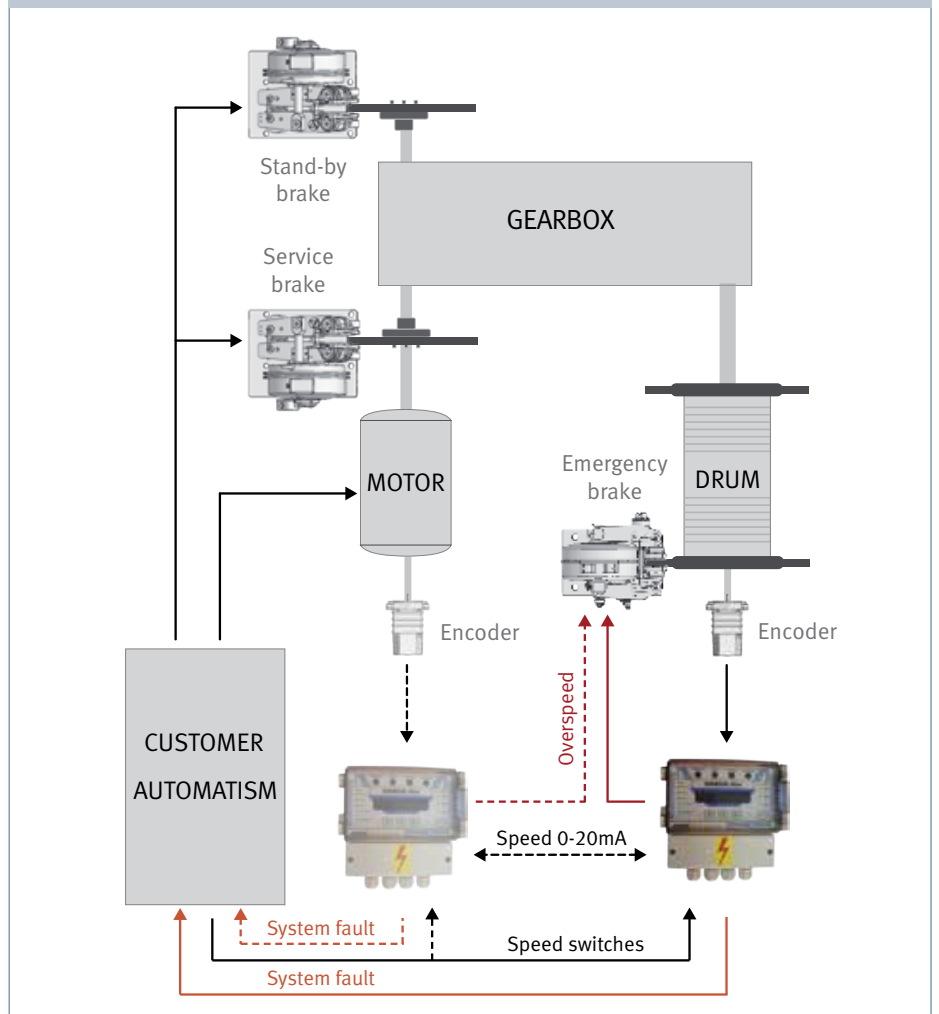

BRAKE DISCS AND COUPLINGS



As a complement to its disc brakes, **GKN Stromag France** proposes three types of disc couplings to offer a complete braking system solution.

GKN Stromag France provides solid and ventilated discs with an external diameter from 175 to 995 mm, and a thickness of 15 mm (monobloc disc), 30 mm (solid and ventilated) or 42 mm (ventilated disc).

> SDF RANGE

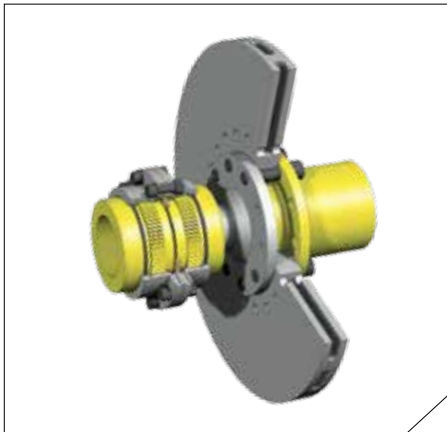

The **SDF** Coupling is a Double Engagement Gear Coupling manufactured with two flanged sleeves with internal spur gear teeth, connected with a set of heat treated alloy steel fasteners and meshed with accurately matched, machined and ground crown toothed hubs.

The closely controlled quality of the gearing profile contributes to minimum end float to obtain the best possible alignment.

> PERIFLEX® RANGE



The **Stromag Periflex®** Shaft Coupling is a Highly-Flexible rubber / fabric tyre type coupling. Due to the unique design of this coupling, the **Periflex®** Shaft Coupling can overcome extreme offsets with low transmittable forces, and without suffering any wear.

It can be mounted and dismantled radially without the necessity of moving the connected machines.

> SDD - SDDL RANGE

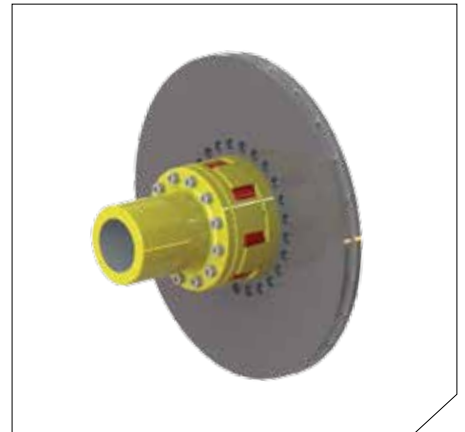

The **SDD** Coupling is a Highly-Flexible coupling which transmits the torque through a firmly fitted elastomeric element.

It is an inserted element type coupling allowing for easy assembly and dismantling of the complete coupling and cam ring.

In the standard version, the **SDD** coupling is equipped with a cam ring and has an “A shore” hardness flexible element. This coupling can be used in temperatures of between -30°C + 100°C.

GKN Land Systems© 2015

PO Box 55,
Ipsley House,
Ipsley Church Lane,
Redditch,
Worcestershire B98 0TL
P: +44 (0)1527 517 715

INTEGRATED POWERTRAIN COMPONENTS, SYSTEMS AND SOLUTIONS



FROM POWER SOURCE >



> TO POWER APPLIED

Stromag

SIME Brakes

GKN Stromag France

20, allée des Erables, BP 40004, ZI Paris Nord II,
95811 ROISSY Charles de Gaulle Cedex,

Tel. : +33 (0)1 49 90 32 22

Fax. : +33 (0)1 49 89 06 38

E-mail : sales@gkn.com

www.stromagfrance.com

The GKN Stromag AG
is a company of GKN Land Systems



Find out more about GKN Stromag
global trade representatives